

MADE IN
USA

TOMCAT



Out Performs
Propane



MICRO RIDER



LARGE RIDERS



AUTOMATICS



200 270 Walk Behind Burnishers

Tomcat Burnishers bring propane quality shine and productivity to the battery field. The walk behind's tough construction, compact size and superior performance make it the batter burnisher of choice.

The hard, high-gloss shine developed by Tomcat is due to the unique burnishing head and flexible pad design. The head is ideally balance and fully floating to provide a long lasting finish over uneven floor surfaces. The burnishing deck is protected under the machine, and the machine tips back permitting quick pad changes. Pad pressure is variable, and a deluxe instrument cluster is standard, including an hour meter to assist with preventive maintenace scheduling.

Dust control is a standard feature, which eliminates the need to dust mop the floor after burnishing is complete. The dust collection bags are easily removed for disposal and extra bags can be stored on the machine.

The Tomcat has a powerful traction drive, which is totally sealed, all-gear and maintenance free. It makes driving the machine an enjoyable task and climbing ramps a breeze. The Tomcat is built to last, but maneuvers through congested areas with ease. The optional onboard charger gives operators the ability to burnish across a larger area, and the independence to recharge at any wall outlet.



EASY PAD ACCESS

Productivity Comparison

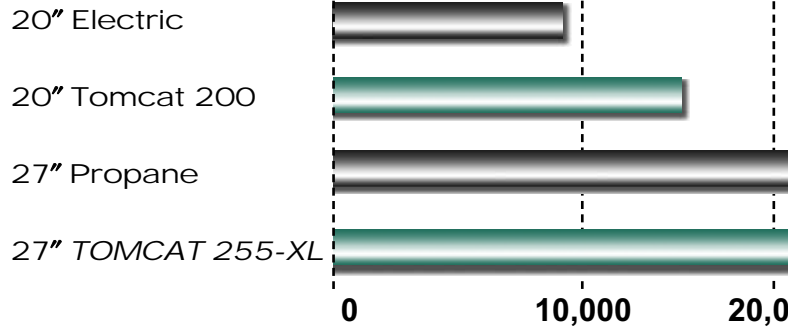

Productivity of a Rider . . . S

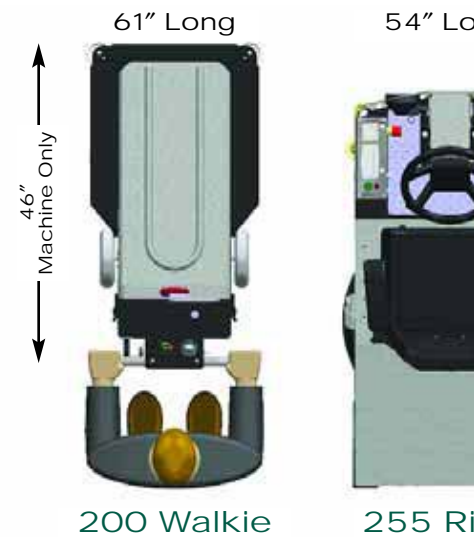

Stainless Components
 • 100% Fasteners
 • Handlebar
 • Hinges



Smaller than Most Walk Behinds

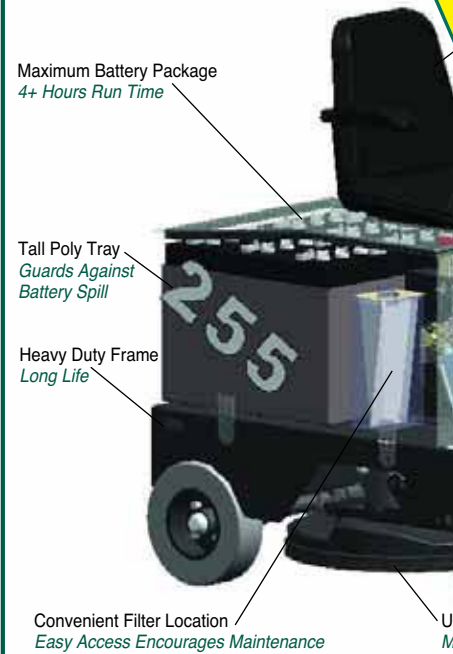

square feet/hour)

00 30,000

FITS ELEVATORS



ONLY 26" WIDE

Smaller than a Walk Behind

58" Long

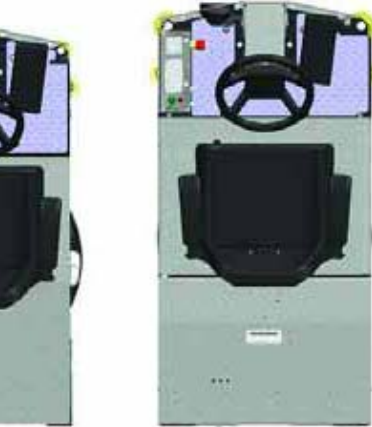

275 Rider

Rider Burnishers

255

Now you can have a Rider burnisher that is actually **SMALLER** than most walk behinds on the market. The **TOMCAT 255 Micro Rider** has double the battery of the walk behinds and 35% wider burnishing path. The **255-XL** boasts a 27" path and can be equipped to run over 4 hours on a single charge, which is enough to polish over 140,000 square feet.

Like all **TOMCAT** burnishers, the **255** is quiet, fume-free, and can eliminate the problems associated with propane equipment. Dust control is standard, along with a comfortable operator's position.

The Pad Pressure is variable, and our flexible pad driver combined with the floating head design delivers a superior finish. Both riders utilize our unique pad drive design which maintains the pad's rpm over uneven floors, and travel speed automatically slows down when polishing.

275

The **TOMCAT 275** is the only rider burnisher built that can operate for 8 hours continuously. No need to change batteries or operate multiple machines to complete the large jobs. Gone are the days when a customer had to sacrifice the performance of propane to achieve the convenience and safety of battery. When properly equipped, the **275** can polish nearly 250,000 sq. feet without stopping.

Call (800) 450-9824 for a Demonstration

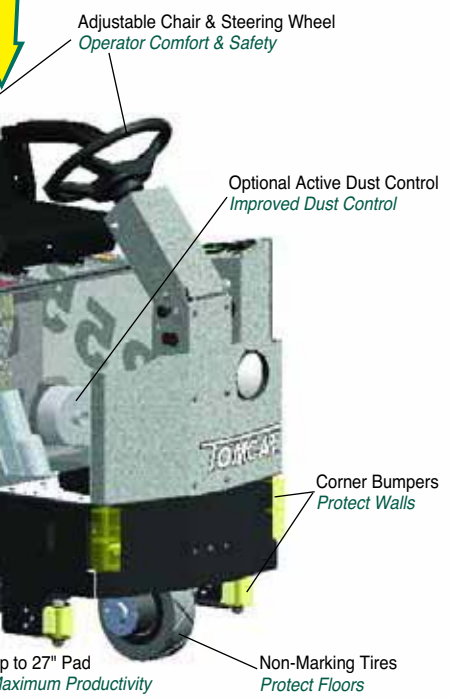

Adjustable Chair & Steering Wheel
Operator Comfort & Safety

Optional Active Dust Control
Improved Dust Control

Corner Bumpers
Protect Walls

Up to 27" Pad
Maximum Productivity

Non-Marking Tires
Protect Floors

Operates a Full 8-Hour Shift

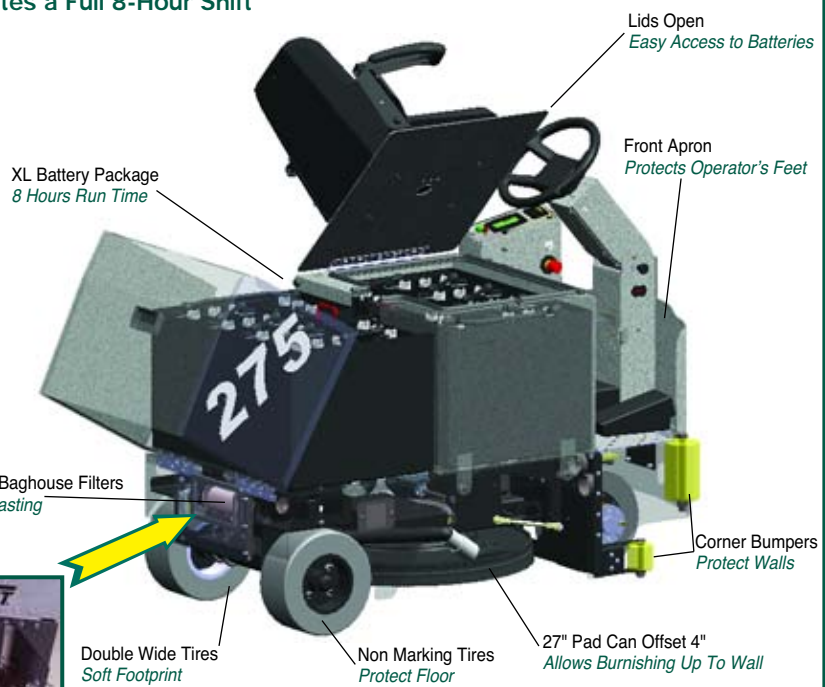

Lids Open
Easy Access to Batteries

XL Battery Package
8 Hours Run Time

Front Apron
Protects Operator's Feet

Optional Baghouse Filters
Longer Lasting

Corner Bumpers
Protect Walls

Double Wide Tires
Soft Footprint

Non Marking Tires
Protect Floor

27" Pad Can Offset 4"
Allows Burnishing Up To Wall



RIDER RETURN ON INVESTMENT

Area (Sq. Ft.)	20" Battery Walk Behind	27" Battery Rider	Savings Monthly
10,000	\$ 137.00	\$ 61.00	\$ 76.00
25,000	\$ 343.00	\$ 152.00	\$ 190.00
50,000	\$ 687.00	\$ 305.00	\$ 381.00
100,000	\$1,375.00	\$ 611.00	\$ 763.00
150,000	\$2,062.00	\$ 916.00	\$1,143.00
250,000	\$3,437.00	\$1,527.00	\$1,909.00

**Based on a total labor cost of \$10/hour.*

SOLD THROUGH DISTRIBUTORS

We are building our reputation by providing the toughest, best-engineered, highest-value machines our industry can produce. We make sure that in every market in which our 330 **TOMCAT** distributors do business, they maintain a factory-trained service department with a vested interest in our customers' long-term satisfaction.

We offer a line of cleaning equipment that includes sweepers, automatic scrubbers, and burnishers, in both walk-behind and rider models. **TOMCATs** are practical, rugged machines that are priced sensibly. Your local distributor can assist you with machine rentals, soap, and floor sealer information. They will gladly provide service on many brands of equipment.

GUARANTEED SERVICE

We guarantee to supply you with the spare parts you need within three work days – or they're yours free. This applies only to the 48 contiguous states, at the customer's special request, and to parts that can be shipped by courier.

TOMCAT

Manufactured By:
RPS Corporation
P.O. Box 241
Racine, Wisconsin 53401
Phone: (800) 450-9824
Fax: (866) 632-6961
www.tomcatequip.com



Copyright RPS Corporation 2007. All rights reserved.
Since our policy is one of constant improvement, all specifications are subject to change without notice.

Model Type	200/270 Walk Behinds	255 Micro Rider	275 Compact Rider
Construction			
Frame (Powder Coated Steel):	10-ga. (1/8")	7-ga. (3/16")	7-ga. (3/16")
Rear Axle Capacity:	1,200 lbs.	5,200 lbs.	5,200 lbs.
Rear Wheels (non-marking):	(2) 8" x 2"	(2) 12" x 3.5"	(2) 12" x 5"
Front Wheel (non-marking):	(2) 4" x 2"	(1) 10" x 3"	(1) 12" x 4"
Dimensions (L x W x H):	44" x 24" x 40"	54.5" x 25" x 50"	58" x 30" x 50"
Weight (w/batteries):	602 lbs.	1,007 lbs.	1,566 lbs.
Weight (w/o batteries):	274 lbs.	714 lbs.	846 lbs.
Burnishing System			
Pad Diameter:	(1) 20"	255: (1) 20" 255-XL: (1) 27"	(1) 27"
Pad Motor Power:	200: (1) 3.0 hp 270: (1) 3.25 hp	(1) 4.0 hp	(1) 4.0 hp
Pad Speed:	200: 2000 rpm 270: 1800 rpm	255: 2000 rpm 255-XL: 1300 rpm	1300 rpm
Pad Engagement:	Direct	255: Direct 255-XL: Dual Belt	Dual Belt
Variable Pad Pressure:	10-65 lbs.	10-75 lbs.	10-75 lbs.
Pad Driver:	Flexible	Flexible	Flexible
Battery System			
Batteries (std.):	(3) 12-v/210 ah	(3) 12-v/210 ah	(6) 6-v/396 ah
Batteries (opt.):	(6) 6-v/245 ah	(6) 6-v/396 ah	(12) 6-v/396 ah
Battery Run Time:	Up to 3 hours	Up to 4 hours	Up to 8 hours
Charger (110v/60 Hz/auto.):	36 volt/25 amp	36 volt/36 amp	36 volt/36 amp
Filtering System			
Vacuum Description:	Passive	Passive or Active	Passive or Active
Filtering Material:	Polymer Felt	Polymer Felt	Polymer Felt
Filter Rating:	1 Micron	1 Micron	1 Micron
Screen Material:	NA	NA	Stainless Steel
Vacuum Power (opt.):	NA	0.75 hp	0.75 hp
Drive System			
Transport Power:	0.5 hp	1.0 hp	2.0 hp
Forward Speed Control:	0-4.5 mph	0-4.5 mph	0-5 mph
Reverse Speed Control:	0-3 mph	0-3 mph	0-3 mph
Braking System:	Dynamic	Dynamic	Dynamic
Min. Aisle for U-Turn:	46"	56"	63"
Productivity			
Cleaning Rate/Hour (Max):	200: 35,248 sq. ft./hr. 270: 45,000 sq. ft./hr.	45,000 sq. ft./hr.	45,000 sq. ft./hr.
Cleaning Rate/Hour (norm.):	200: 24,421 sq. ft./hr. 270: 34,817 sq. ft./hr.	34,817 sq. ft./hr.	34,817 sq. ft./hr.
General			
Sound Level (@ driver's position):	68 dBA	70 dBA	70 dBA
Gradeability:	11 degrees/19%	11 degrees/19%	11 degrees/19%
Optional Equipment	Onboard Charges, Headlight, Strobe, Backup Alarm, Maintenance Free Batteries		

AUTHORIZED DISTRIBUTOR